

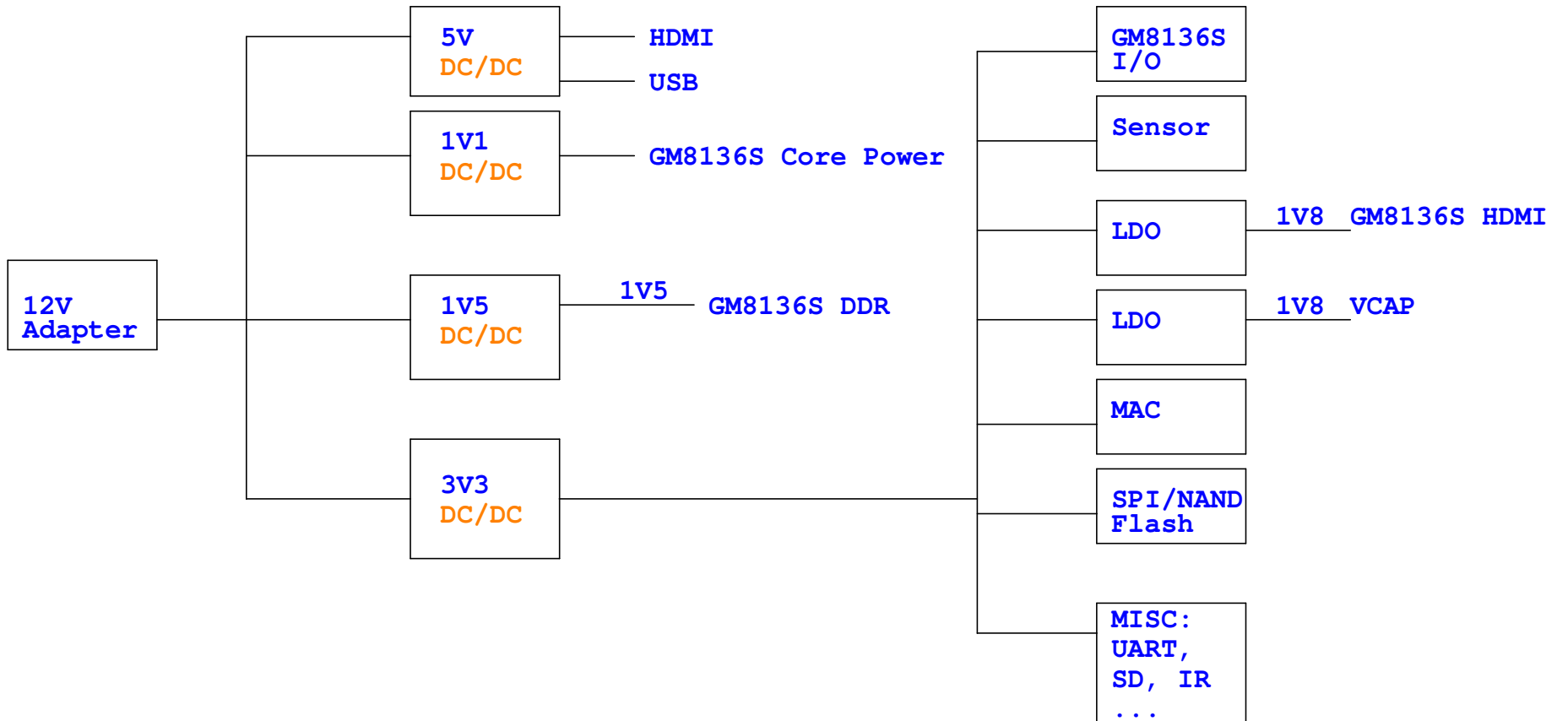

# Revision

Date	Rev	Description/Change List	Page	Date	Rev	Description/Change List	Page
			1				8
			2				9
			3				10
			4				11
			5				12
			6				13
			7				14

				
Title: <b>Revision History</b>				
Size: A3	Document Number: GM8136S LQFP128 EVB	Department: MTD/SE2	Designer: Wayne Ko	Rev: 1V0
Date: Friday, October 24, 2014	Sheet: 2 of 17			



**Grain Media, Inc.**

Title: <b>Power Block</b>				
Size: A4	Document Number: GM8136S LQFP128 EVB	Department: MTD/SE2	Designer: Wayne Ko	Rev: 1V0
Date: Friday, October 24, 2014	Sheet: 3 of 13			

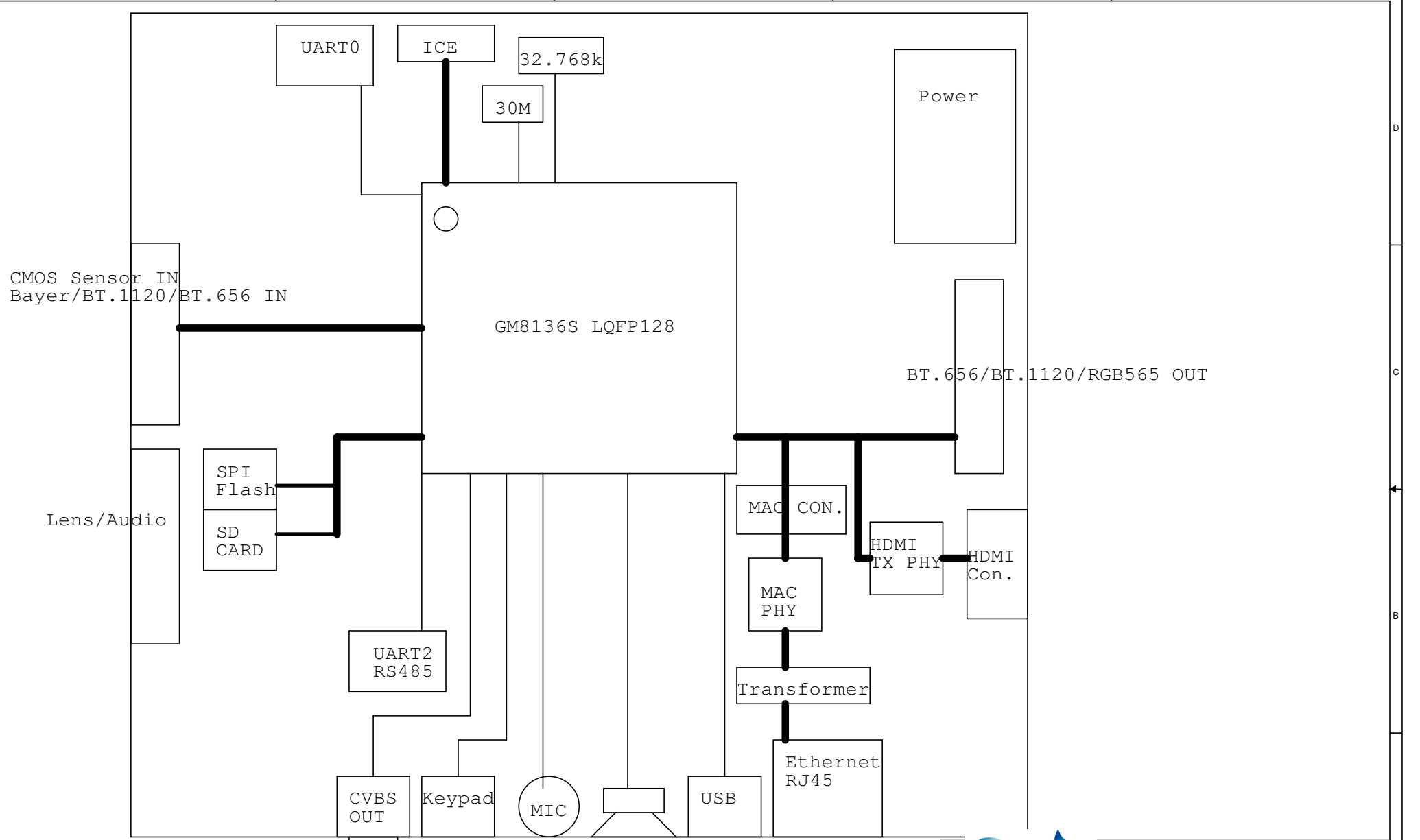

**Grain Media, Inc.**

Title: <b>Block Diagram</b>				
Size: A4	Document Number: GM8136S LQFP128 EVB	Department: MTD/SE2	Designer: Wayne Ko	Rev: 1V0
Date: Friday, October 24, 2014		Sheet: 4 of 13		



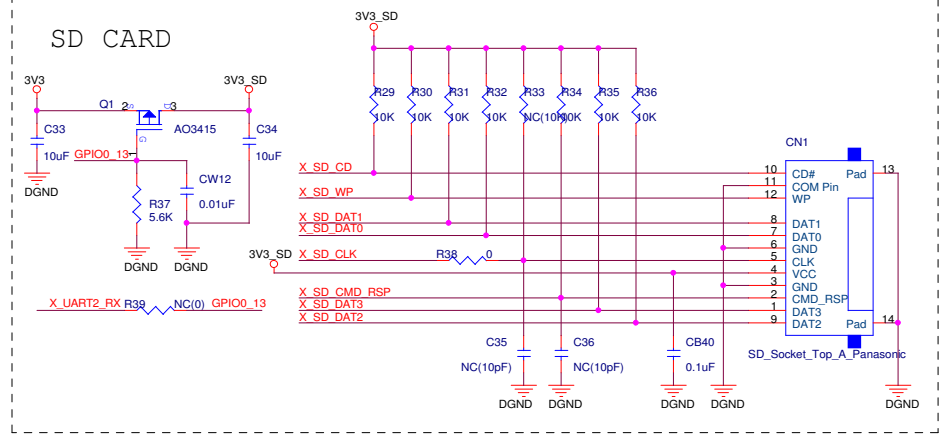
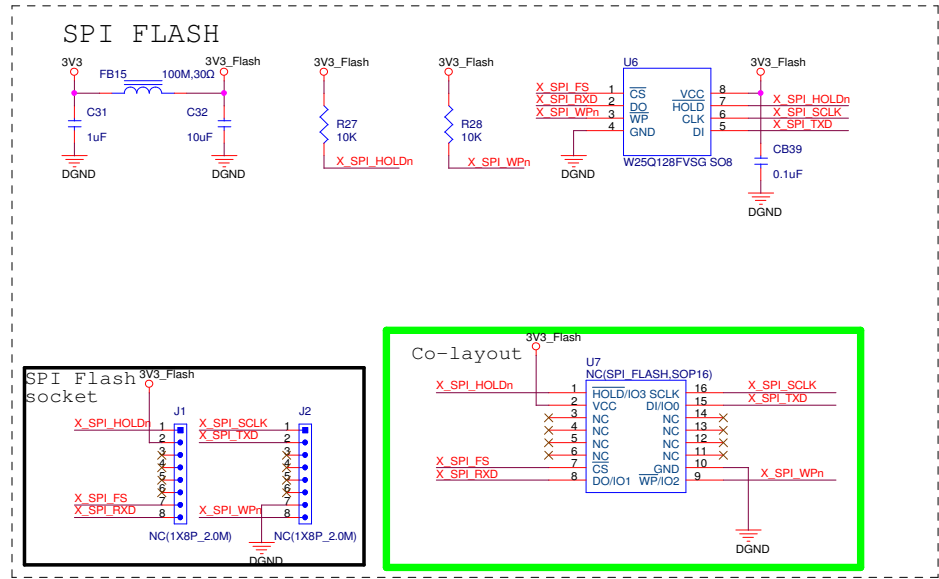
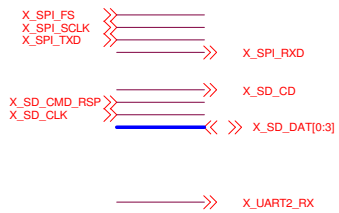

**Grain Media, Inc.**

Title: <b>FLASH</b>				
Size: A3	Document Number: GM8136S LQFP128 EVB	Department: MTD/SE2	Designer: Wayne Ko	Rev: 1V0
Date: Friday, October 24, 2014	Sheet: 6 of 13			

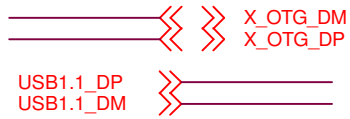

Closed to Source

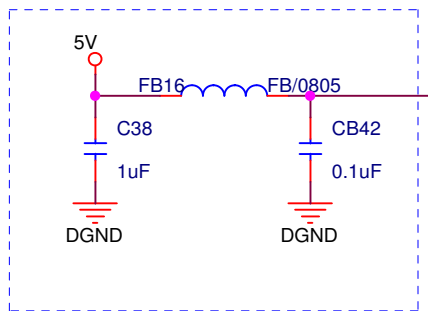

Closed to CN2

5V, VBUS: W>= 25mils

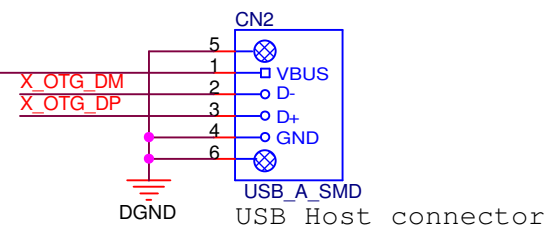
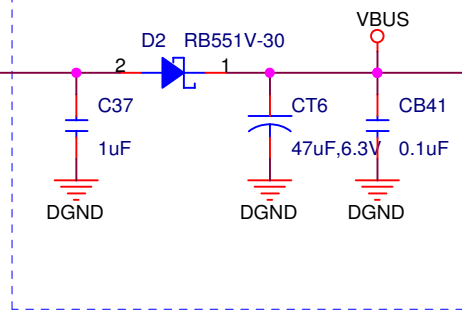

DP, DM  
Differential Trace Impedance 90 ohms

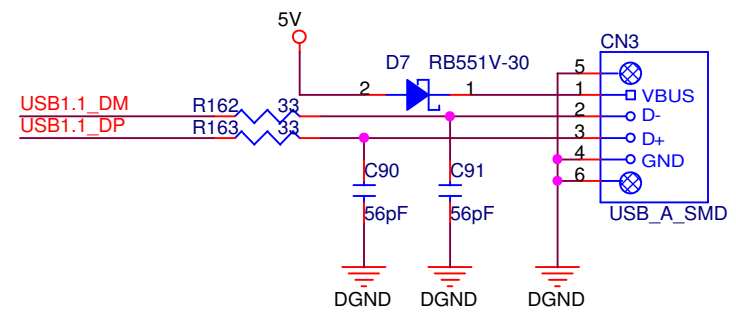
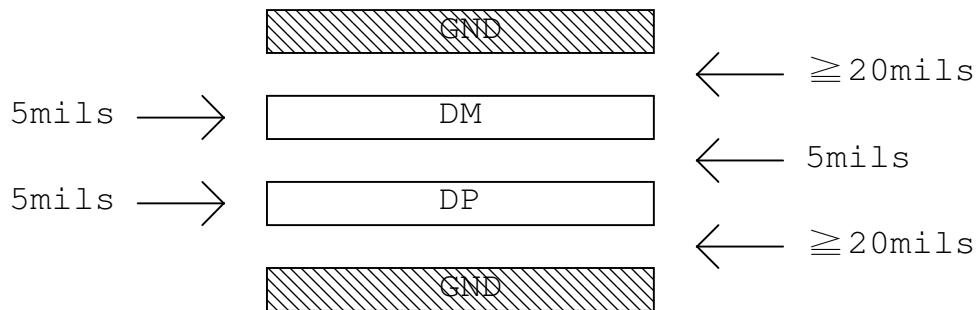

Title: <b>USB HOST</b>				
Size: A	Document Number: GM8136S LQFP128 EVB	Department: MTD/SE2	Designer: Wayne Ko	Rev: 1V0
Date: Friday, October 24, 2014	Sheet: 7 of 13			

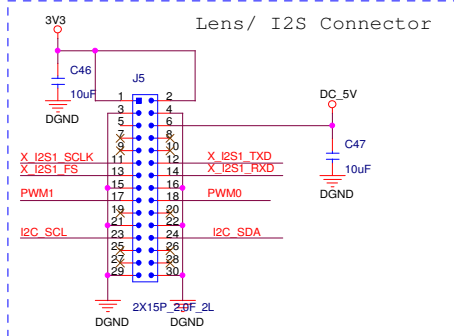
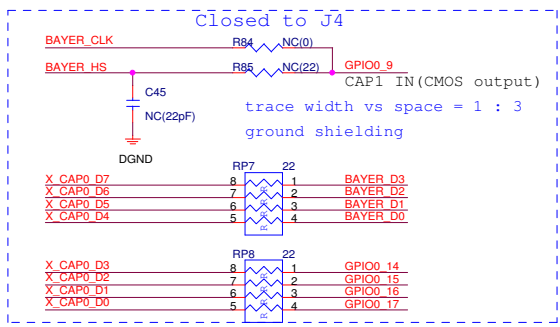
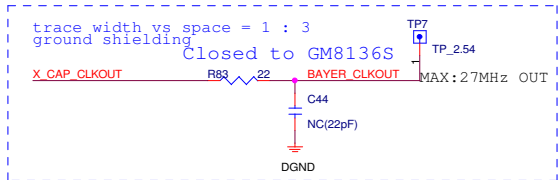
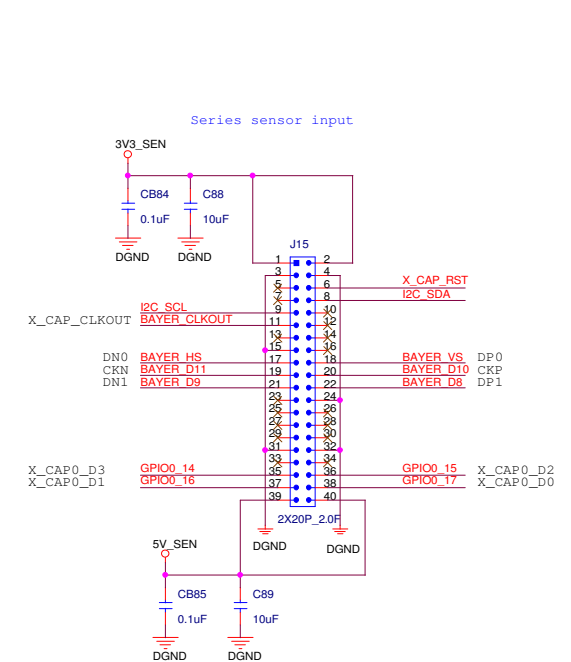
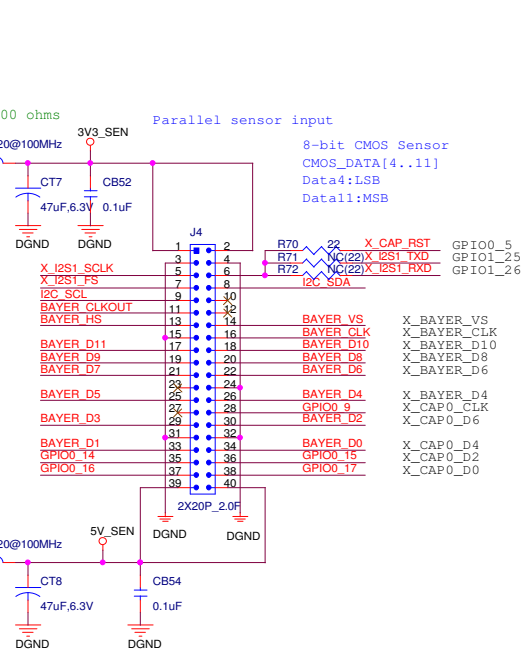
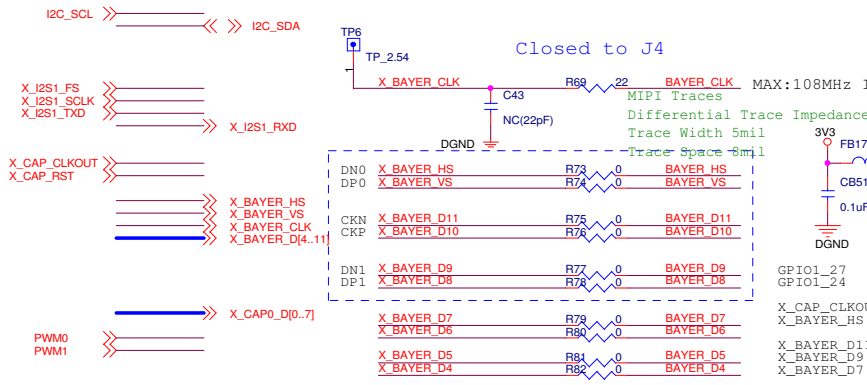

	I2C	SPI
CAP0_D3	I2C_SCL	SPI_FS
CAP0_D2	I2C_SDA	SPI_RXD
CAP0_D1		SPI_TXD
CAP0_D0		SPI_SCLK

	Bayer 12 IO power 3.3/2.8/1.8V	Bayer 10 IO power 3.3/2.8/1.8V	Bayer 8 3.3/2.8/1.8V	BT656 +BT656	BT1120 16	BT601 16	MIPI/ Sub-LVDS	MIPI/ Sub-LVDS +BT656
Bayer_CLK	CLK	CLK	CLK	D656_1_CLK	CLK	CLK		D656_0_CLK
Bayer_HS	HS	HS	HS	D656_0_CLK		HS	DN0	DN0
Bayer_VS	VS	VS	VS			VS	DP0	DP0
Bayer_D11	D11	D9	D7	D656_1_7	Y7	Y7	CKN	CKN
Bayer_D10	D10	D8	D6	D656_1_6	Y6	Y6	CKP	CKP
Bayer_D9	D9	D7	D5	D656_1_5	Y5	Y5	DN1	DN1
Bayer_D8	D8	D6	D4	D656_1_4	Y4	Y4	DP1	DP1
Bayer_D7	D7	D5	D3	D656_1_3	Y3	Y3		
Bayer_D6	D6	D4	D2	D656_1_2	Y2	Y2		
Bayer_D5	D5	D3	D1	D656_1_1	Y1	Y1		
Bayer_D4	D4	D2	D0	D656_1_0	Y0	Y0		
CAP0_D7	D3	D1		D656_0_7	C7	C7		D656_0_7
CAP0_D6	D2	D0		D656_0_6	C6	C6		D656_0_6
CAP0_D5				D656_0_5	C5	C5		D656_0_5
CAP0_D4				D656_0_4	C4	C4		D656_0_4
CAP0_D3				D656_0_3	C3	C3		D656_0_3
CAP0_D2				D656_0_2	C2	C2		D656_0_2
CAP0_D1				D656_0_1	C1	C1		D656_0_1
CAP0_D0				D656_0_0	C0	C0		D656_0_0

**Grain Media, Inc.**

Title: CMOS Sensor

Size: A3 Document Number: GM8136S LOFP128 EVB Department: MTD/SE2 Designer: Wayne Ko Rev: 1V0

Date: Monday, December 08, 2014 Sheet: 8 of 13



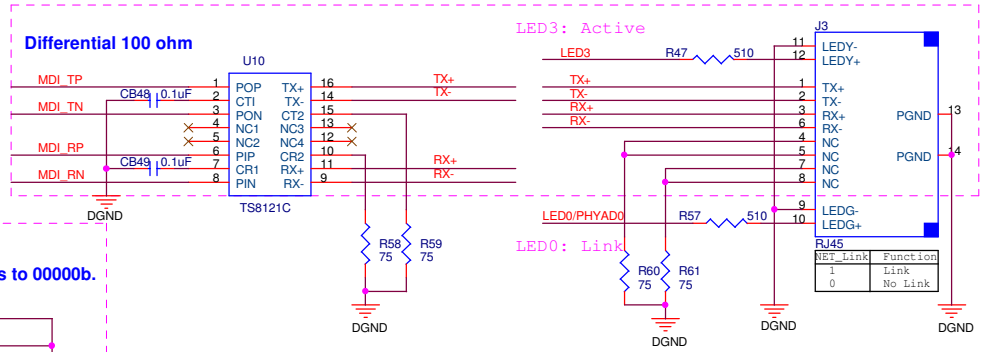
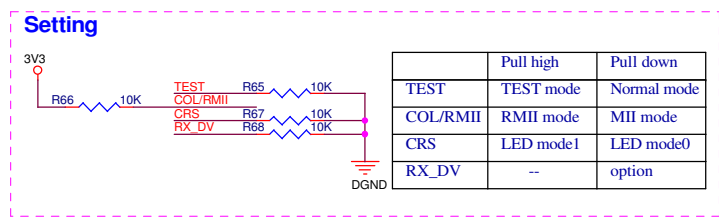
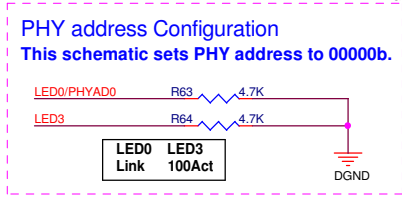
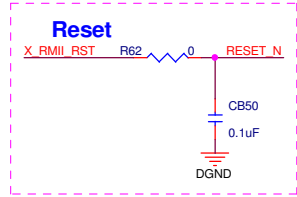
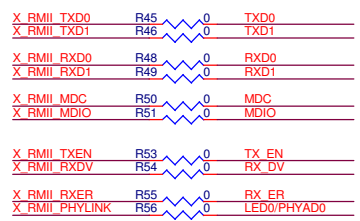
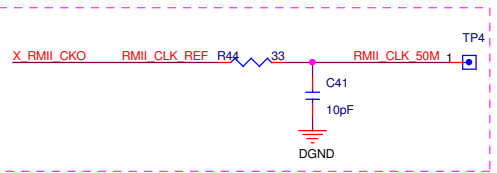
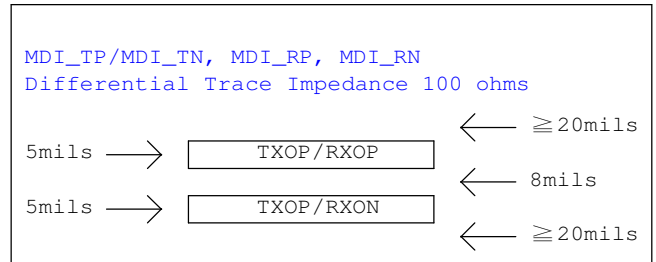
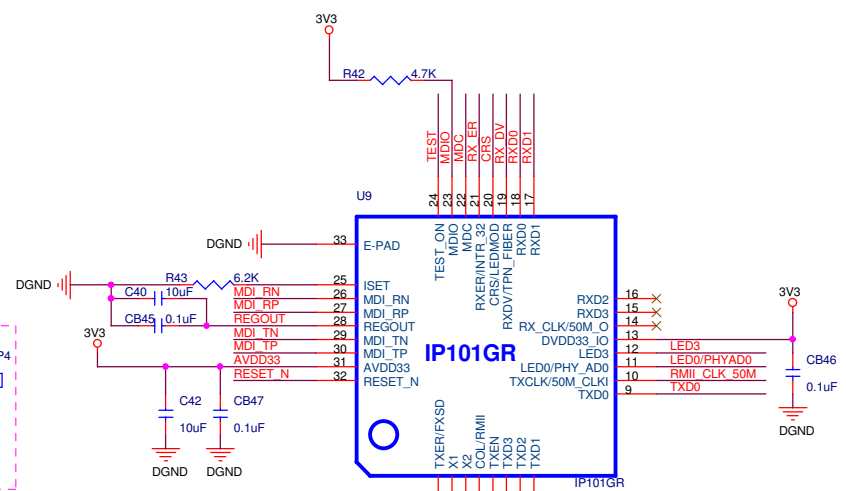
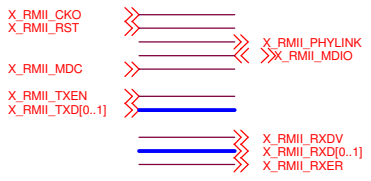

**Ethernet**

Title: Ethernet

Size: B	Document Number: GM8136S LQFP128 EVB	Department: MTD/SE2	Designer: Wayne Ko	Rev: 1V0
Date: Friday, October 24, 2014	Sheet: 9 of 13			

X\_ICE\_TDO  
 X\_ICE\_TRSTn  
 X\_ICE\_TDI  
 X\_ICE\_TMS  
 X\_ICE\_TCK

X\_UART0\_TX  
 X\_UART0\_RX

X\_UART2\_TX  
 X\_UART2\_RX

X\_ADC\_AIN0  
 X\_ADC\_AIN1

PWM0

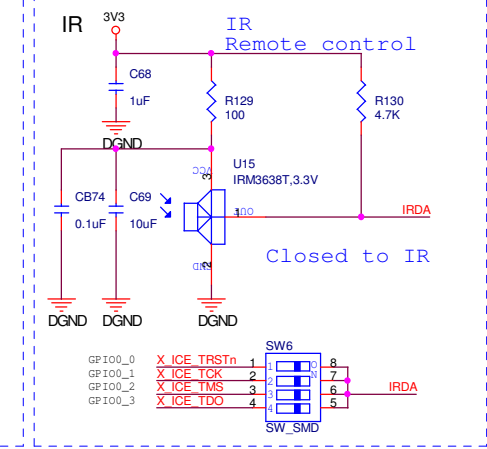
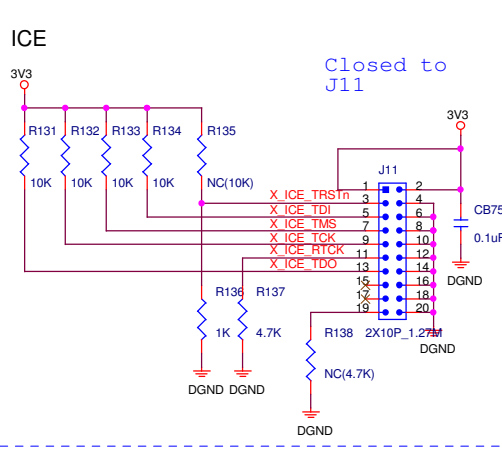
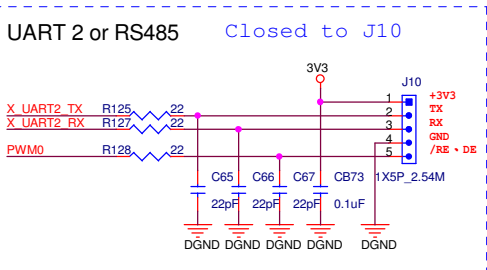
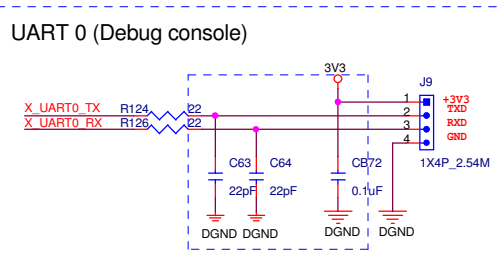

### SAR ADC Closed to J12

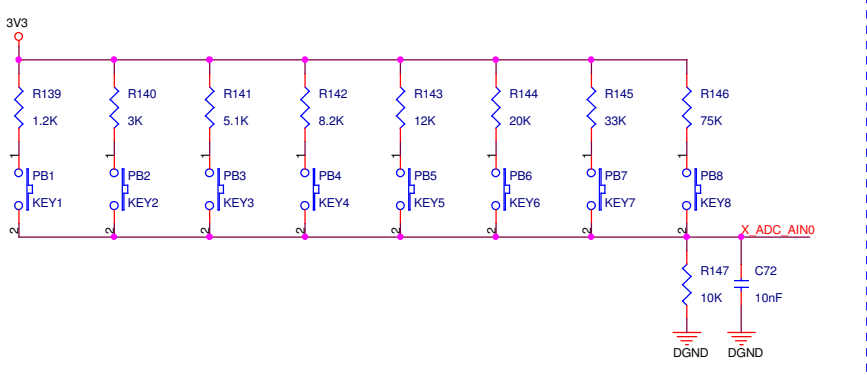
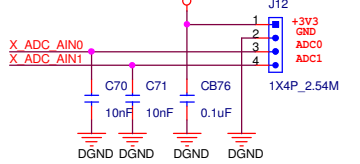

**Grain Media, Inc.**

Title: **MISC**

Size: B	Document Number: GM8136S LQFP128 EVB	Department: MTD/SE2	Designer: Wayne Ko	Rev: 1V0
Date: Friday, October 24, 2014	Sheet: 10 of 13			

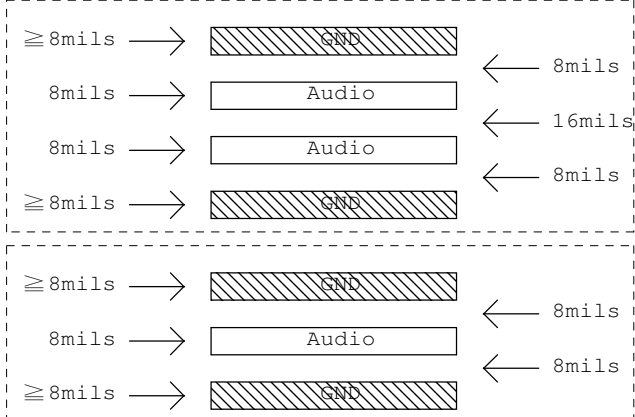
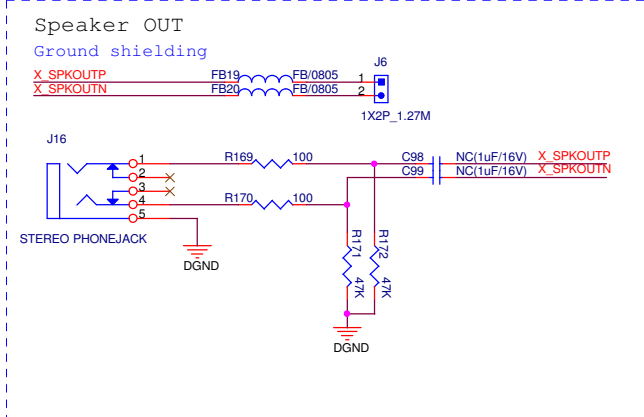
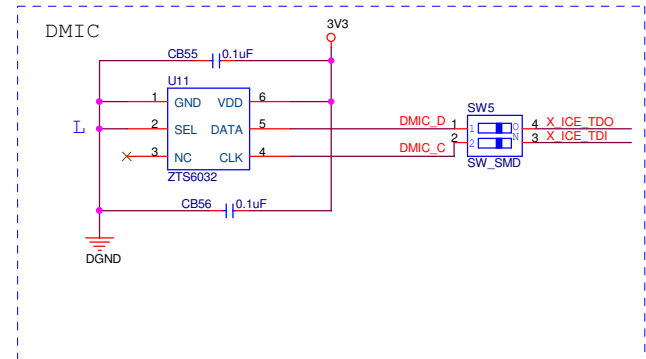
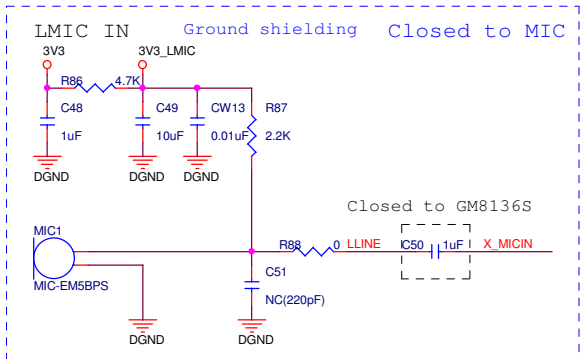
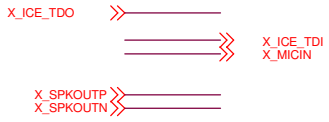

**Grain Media, Inc.**  
 Title: **Audio IN/OUT**  
 Size: B | Document Number: GM8136S LQFP128 EVB | Department: MTD/SE2 | Designer: Wayne Ko | Rev: 1V0  
 Date: Friday, October 24, 2014 | Sheet: 11 of 13



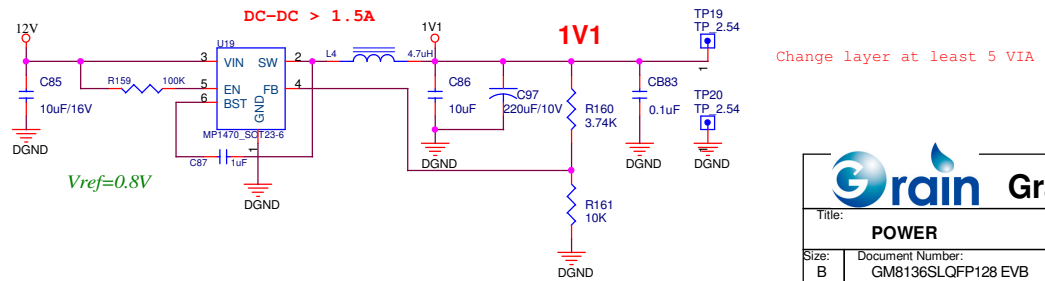
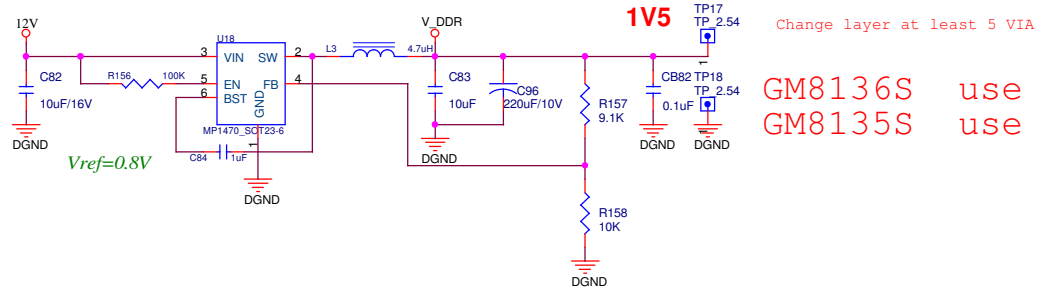
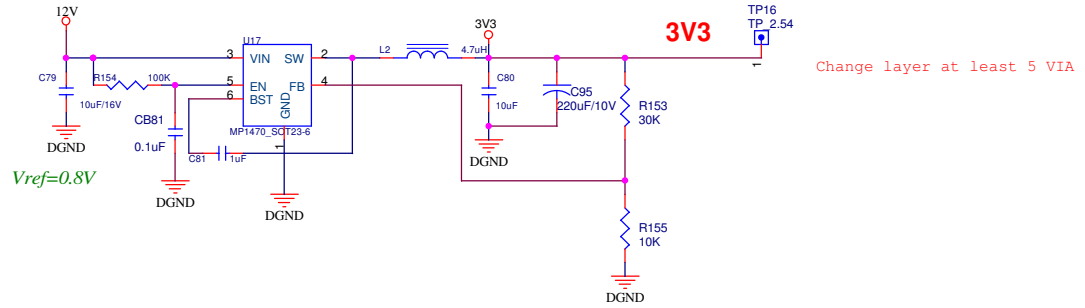
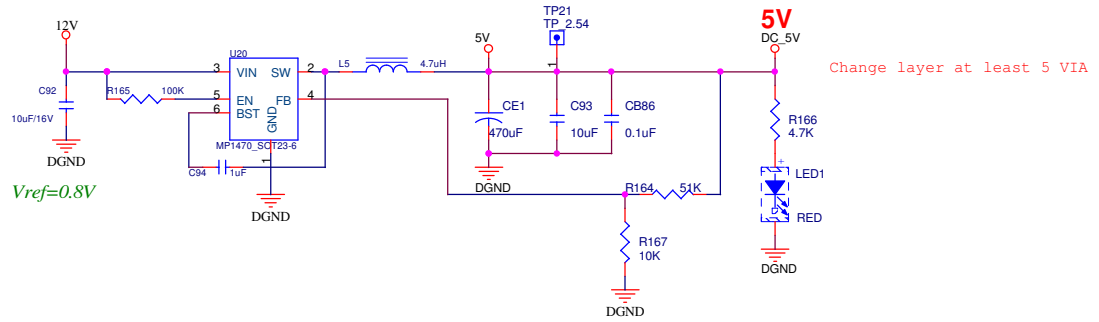
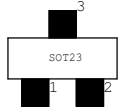
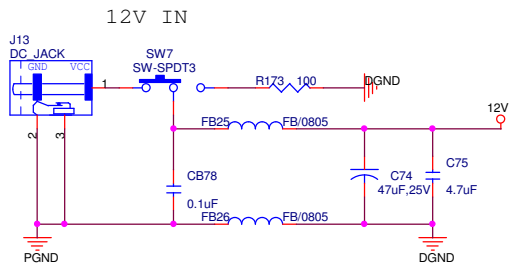

Title: <b>POWER</b>				
Size: B	Document Number: GM8136SLQFP128 EVB	Department: MTD/SE2	Designer: wayne Ko	Rev: 1V0
Date: Friday, October 24, 2014	Sheet: 13	of 13		